

Pump specifications:

Type.....BA-C100H1 D418
 Max. flow345 m³/hour (1518 US GPM)
 Max. pressure..... 100 mwc (330 ft.)
 Connections..... Discharge 4" ANSI
 Connections..... Suction 8" DN200
 Enclosed impeller ... Free passage 16 mm (0.63")
 Priming system BBA MP50
 Engine Perkins 1204E-E44TTA
 Emission standard .. Stage IIIB / Tier 4i
 Canopy EL17-40
 Sound level..... Approx. 70 dB(A) at 10m
 Dry weight.....5.000 kg (11.000 lbs)



FEATURES

BA auto prime pump

The BA range of pumps has been designed with a clear focus on reliability, efficiency and durability. Featuring a 100% mechanical priming system, the BA series pumps quickly prime and re-prime, even from dry conditions. The heavy build style of both pump and canopy make the BA range perfect for use in the strenuous contractor market.

World-class performance

The BA range is built to be deployed on the most demanding dewatering and sewage bypassing applications. Using high efficiency pumps and state-of-the-art diesel engines, the pumps offer maximum performance at minimal cost, fully in-sync with the company philosophy of "Lowest cost of ownership".

Sustainability

- High efficiency pumps minimising fuel consumption
- Corrosion free hot dip galvanised canopy
- Corrosion free composite door panels and powder coated plating
- 100% Oil-spill free priming system
- Fully bunded unit eliminating fuel/oil spills at all times

Complete package designed & built by BBA Pumps

- Complete in-house design & production
- Over 60 years of experience in the market
- Complete testing facility in-house
- Contemporary & functional design
- Durable & eco-friendly materials
- Custom builds available

After sales service & product support

- Single supplier for parts, spares & accessories
- Dedicated customer help-desk (24h service)
- Dedicated service department in-house
- Global parts distribution network
- Optional global on-site servicing available
- Extensive training options available (technical & commercial), on-site or in-house

PERFORMANCE CURVES (1850 RPM)

Continuous duty according ISO 9906

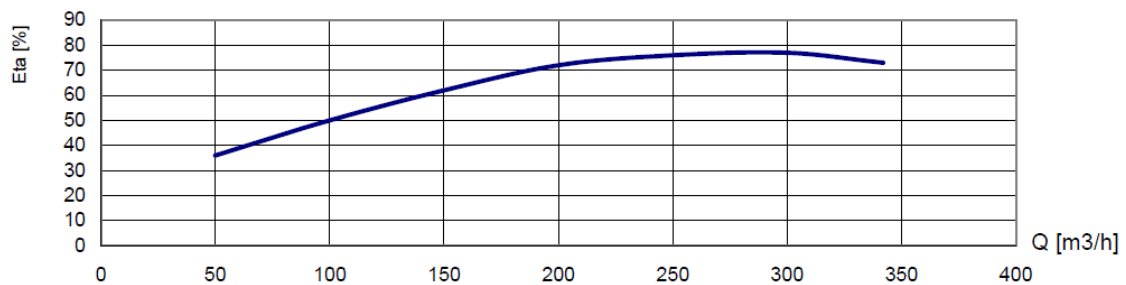
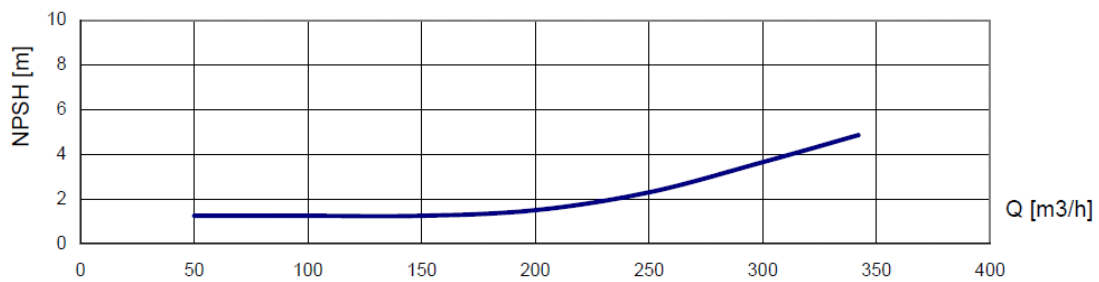
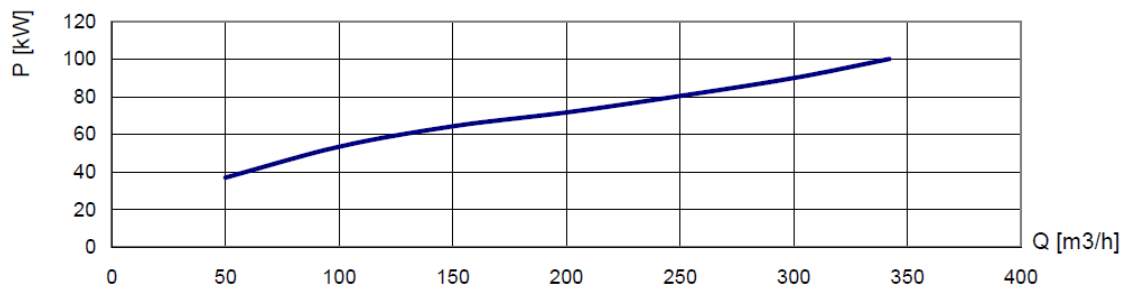
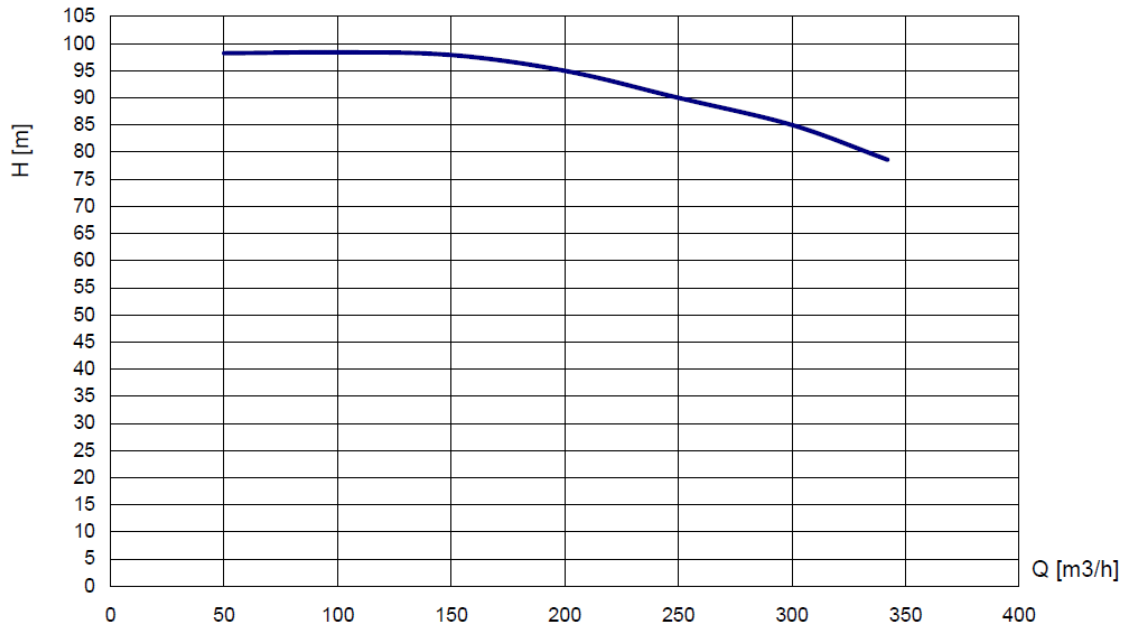

STANDARD TECHNICAL SPECIFICATIONS

BBA auto prime pump

Pump type.....	BA-C100H1 D418
Max. flow.....	345 m ³ /hour (1518 US GPM)
Max. head.....	100 mwc (330 feet)
Impeller type.....	Enclosed impeller
Solids handling.....	16 mm (0.63 inch)
Pump casing.....	Cast iron GG20
Impeller.....	Cast iron GG20
Wear ring.....	Cast iron GG20
Pump shaft.....	Stress-proof SAE 1144
Shaft seal.....	Cycloseal®
Seal faces.....	Tungsten/Sic



BBA priming system

Pump type.....	BBA MP50 Diaphragm pump
Air handling capacity.....	50 m ³ /h (30 CFM)
Max. vacuum.....	8.5 m (29 inHg)
Drive.....	Toothed belt (continuous drive)
Float box.....	Steel galvanized
Float.....	Stainless steel 304
Non return valve.....	Cast iron GG25
Check valve disc.....	Buna-N



Engine

Engine brand.....	Perkins
Engine type.....	1204E-E44TTA
Gross engine power.....	129 kW (175 Hp)
Max. engine speed.....	2200 RPM
Fuel consumption.....	211 g/kWh (1850 RPM 100% load)
Displacement.....	4.4 litres (268.5 cu in)
Number of cylinders.....	4
Aftertreatment.....	DOC and DPF
Fuel specification.....	ULSD 15ppm Sulphur
Emission level.....	Stage IIIB – Tier 4i

BBA control panel LC30

- Auto start/stop system
- Two float switches included (10 m cable)
- Switch Manual-0-Auto
- RAMP-UP/DOWN function
- Rpm. control with push buttons
- Warning lights
- 4.3" LCD monitor

The LCD monitor displays additional engine data, e.g. actual engine speed, working hours, battery voltage, fuel consumption and failures in clear text (10 language support)



Fuel system

- PE fuel tank 300 L. net (80 US Gallon)
- Fuel tank cap Ø 60 mm
- Fitted with water separator & extra in-line fuel filter

Electrical system & safety features

- Premium quality battery
- Low oil pressure shut down
- High temperature shut down

CANOPY EL17-40

BBA sound attenuating canopy

Canopy type.....	EL17-40
Dimensions L x W x H	4000 x 1700 x 2080 mm
Dimensions L x W x H	157.5 x 67 x 82 inch
Basic frame	Hot dip galvanised
Doors	4 Easy-access composite doors (lockable)
Panels	Steel powder coated
Fuel tank	PE net 300 ltr (80 US Gallon)
Fuel tank autonomy	9 hours (at 1850 rpm BEP)
Fuel tank cap	60mm (2.5 inch)
Forklift pockets.....	Fitted with 2 forklift pockets
Lifting point	Fitted with 2 lifting points
Oil drain pump	Drain pump for motor oil installed (hand pump)
Connections	Please consult "auxiliary items"
Exhaust system	Aftertreatment fully integrated in canopy, extra silencer outside
Radiator box	Fitted with quick release system for easy cleaning
Additional	Fitted with oil-water separator
Documentation	User manual & BBA warranty book

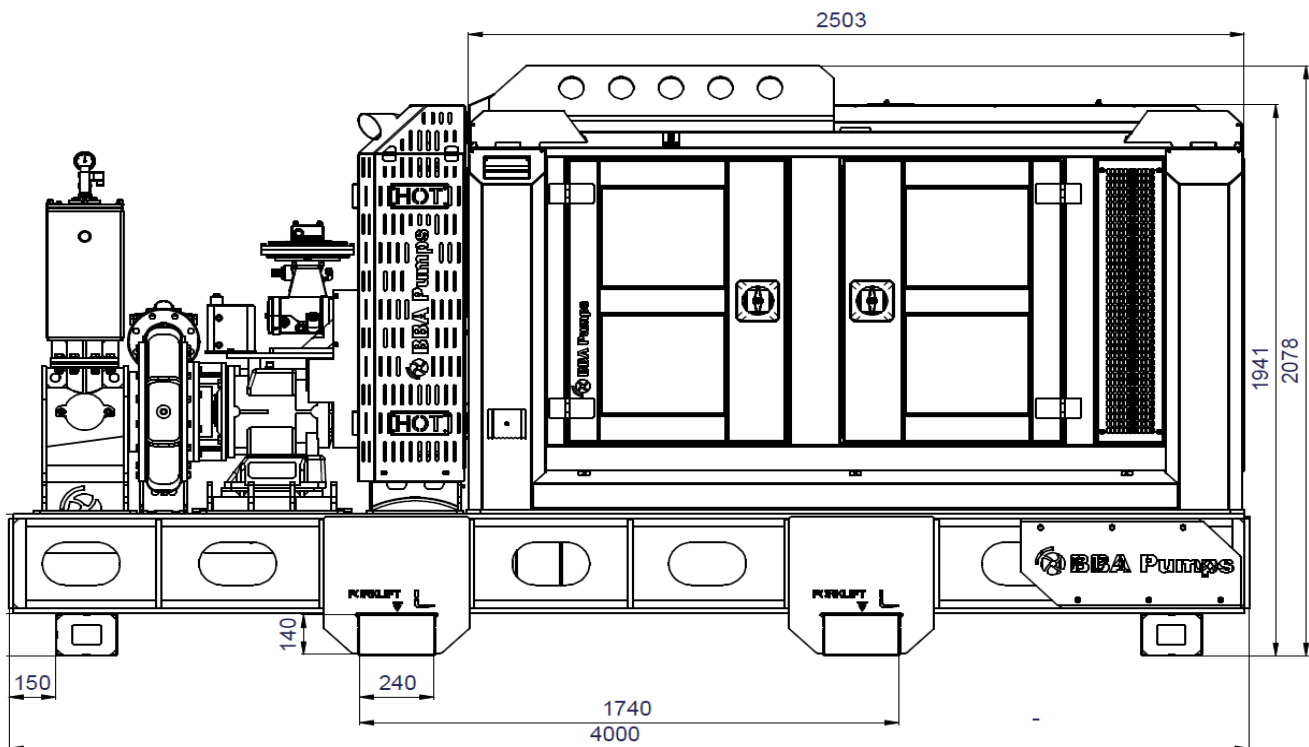

Actual dimensions (in mm) may vary depending on selected quick couplings.

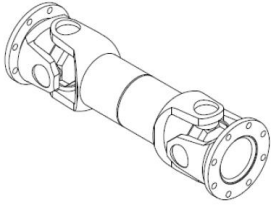

Cardan shaft
Cardan shaft between pump and diesel engine for smooth operation, assembly angle 2.5° - 3°



LED lights
Fully integrated in the canopy for easy operation throughout the evening and night.

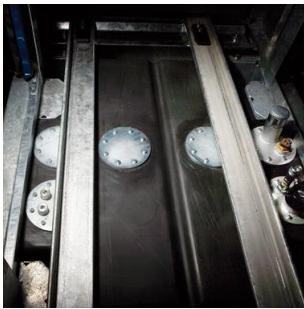

Fuel tank
Fully bunded, corrosion-free, 300 liter, high-density polyethylene (HDPE) fuel tank, located in base of canopy.



Safety
Extremely durable and lockable T-locks offering perfect grip.



Factory Acceptance Test
Extensive testing facility in-house. FAT must be conducted formally and be witnessed by the owner and/or project manager.

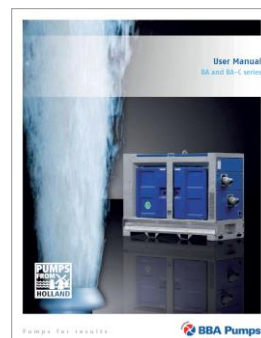

User Manual BA and BA-C
Extensive user manual with important information concerning the pump unit, pump installation and safety warnings. Available in several languages.

Pictures used are for illustration purposes only.